



SEASTAR™
JACKPLATE

HOLE SHOT PLATE KITS

Thank you for purchasing a SeaStar Hole Shot Plate Kit for your SeaStar Jackplate. You will find that your hole shot kit will greatly improve your hole shot performance and getting your boat on plane.

NOTICE

These instructions are intended to be used in conjunction with the SeaStar Jackplate Installation/Assembly Instructions PID# 469349 provided with your Jackplate.

Please Contact SeaStar Solutions if you require a replacement copy.

HSP4060 & HSP4080

⚠ WARNING

CRUSH HAZARD. Moving Jackplate parts can crush. Keep all body parts free and clear when actuating the Jackplate.

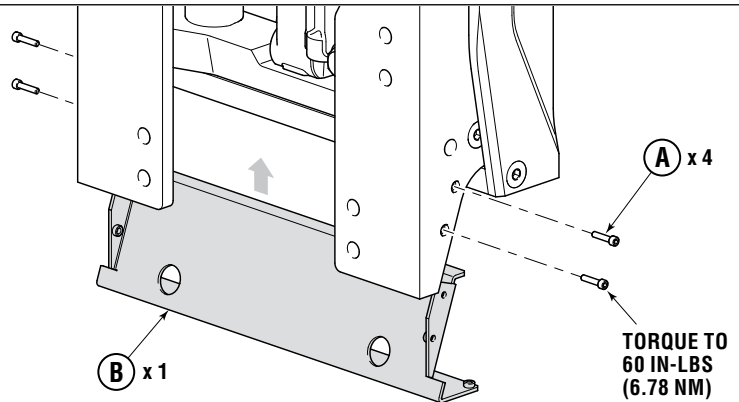

Figure A.

If mounting holes are not present drill $\varnothing.22$ " hole at the locations shown in Figure B.

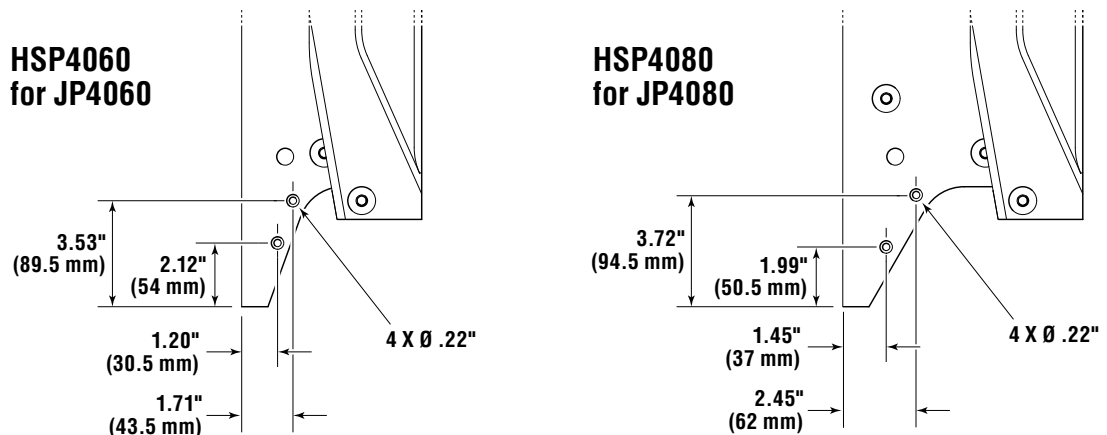

Figure B.



HSP4100 & HSP4120

⚠ WARNING

CRUSH HAZARD. Moving Jackplate parts can crush. Keep all body parts free and clear when actuating the Jackplate.

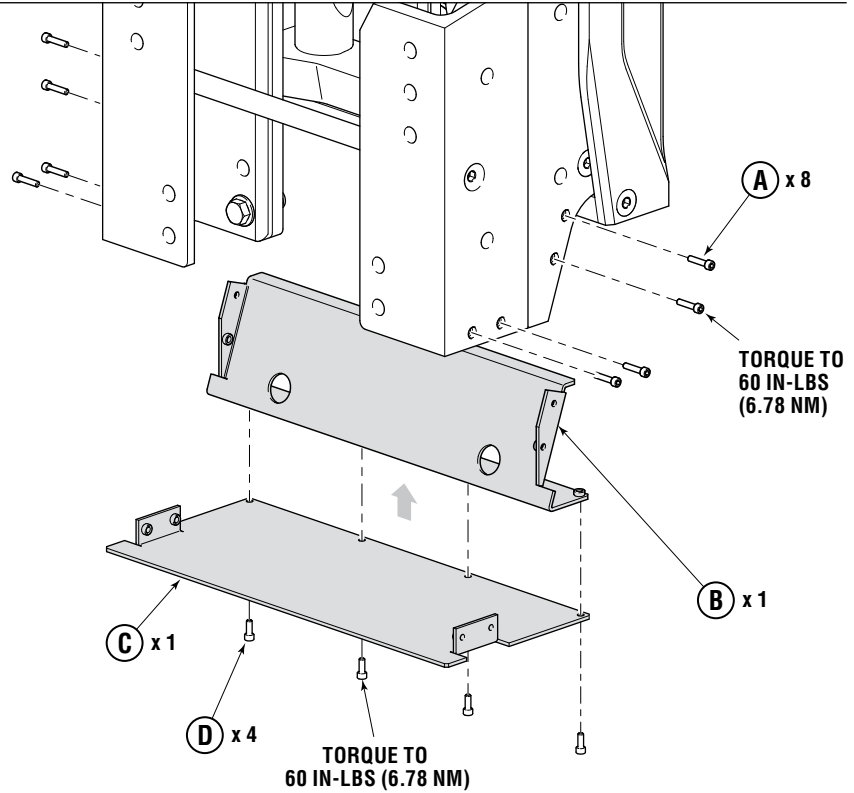

Figure C.

If mounting holes are not present drill $\varnothing.22$ " hole at the locations shown in Figure D.

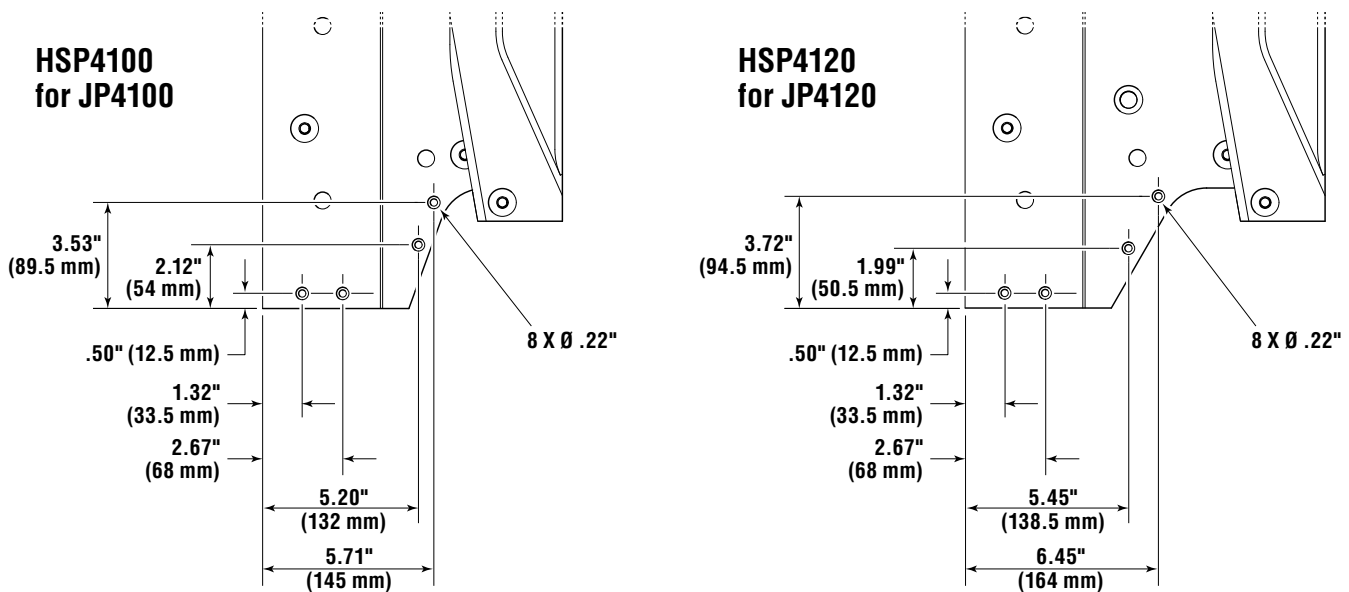

Figure D.