

# ACXENT

LED LINEAR LIGHTING SYSTEM

---



  
MARINE LIGHTING

# PRODUCT DESCRIPTION

A cut to length linear LED solution providing customized overhead and accent lighting for sail and power boats. This revolutionary and cost-effective approach allows boat builders to illuminate interior living spaces in a completely new way, providing for greater product differentiation. The benefit to the customer is an architecturally pleasing appearance that fits perfectly with today's contemporary style trends. During daylight hours when the lighting is turned 'off', there are no protruding parts and this provides for a much cleaner looking interior living area.

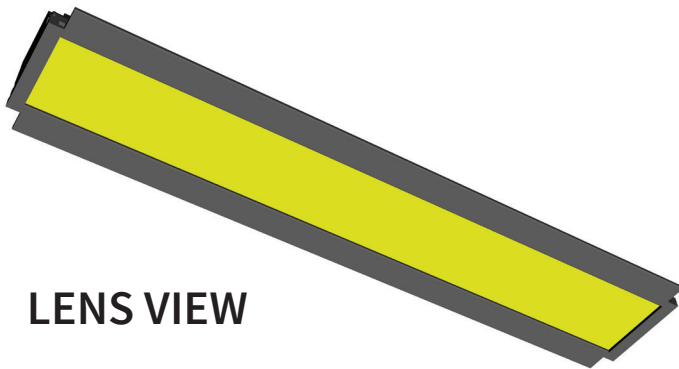

**LENS VIEW**



**HEATSINK VIEW**

# GENERAL SPECIFICATIONS

<b>Housing Material</b>	Anodized Aluminum
<b>Lens (Diffuser) Material</b>	UV Stable PMMA
<b>Cut Increments</b>	2.9" (74 mm)
<b>Input Voltage</b>	24VDC*
<b>Power Consumption</b>	6.4W/ft (305mm)
<b>Luminous Flux</b>	572 lm/ft (305 mm)
<b>Color Correlated Temperature</b>	3000K (warm white)
<b>Color Rendering Index (CRI)</b>	83
<b>Beam Angle (FWHM)</b>	115°
<b>Dimming</b>	PWM input
<b>Ingress Protection</b>	IP40
<b>Certifications</b>	CE-EMC, ROHS

\*Requires constant 24VDC supply voltage +/- 5%

# POWER & LIGHT OUTPUT

	Power Consumption	Luminous Flux
<b>1' Section</b>	6.4W	572 lms
<b>2' Section</b>	12.8W	1144 lms
<b>3' Section</b>	19.2W	1716 lms
<b>4' Section</b>	25.6W	2288 lms
<b>5' Section</b>	32.0W	2860 lms
<b>6' Section</b>	38.4W	3432 lms
<b>7' Section</b>	44.8W	4004 lms
<b>8' Section*</b>	51.2W	4576 lms

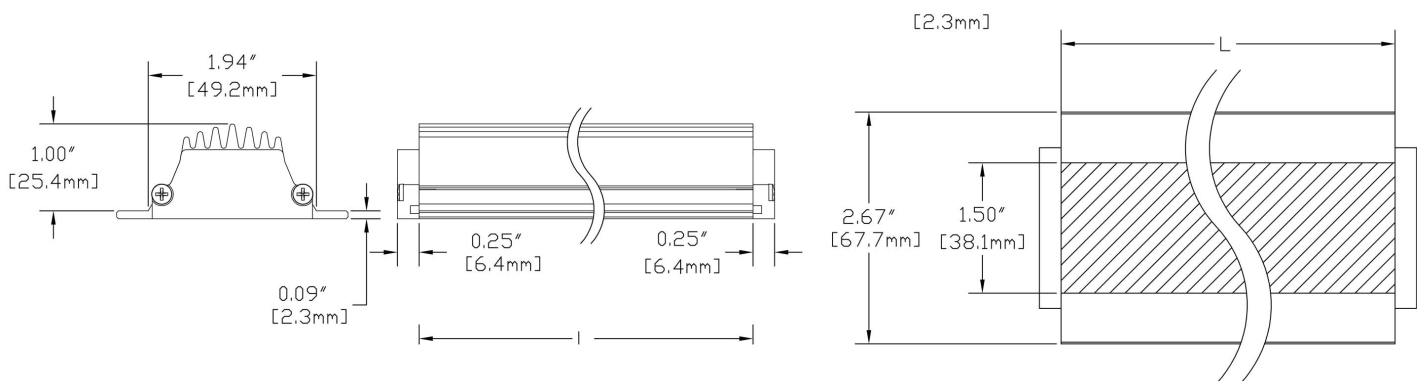

# PHYSICAL INSTALLATION

The Fixture trim edge is hidden behind overlapping headliner or between headliner seams. The only part of the fixture that can be seen is the opaque lens which blends in with its surrounding and isn't perceived when the lights are off. This is the most discreet form of installation and the one most commonly used for living areas aboard yachts.

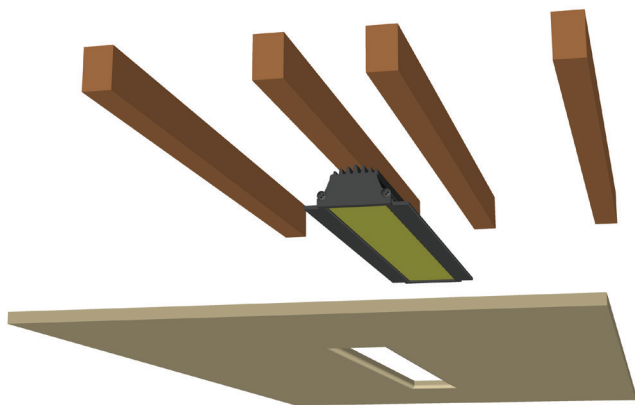
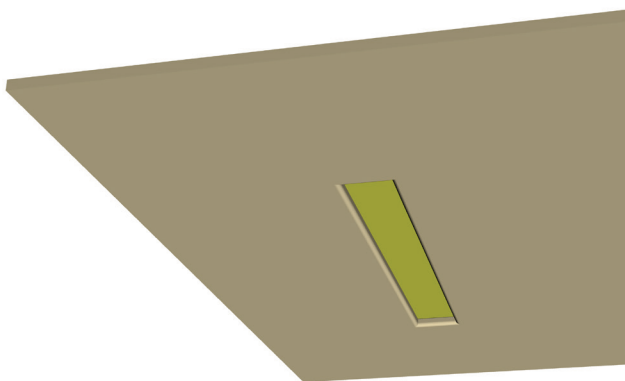
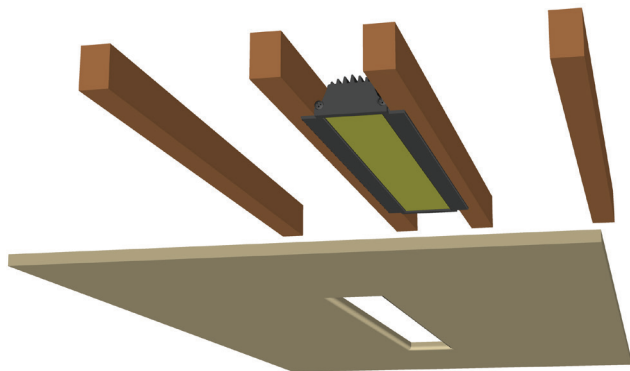

# WIRING INSTRUCTIONS (120V/230V SUPPLY)

1. At the AC panel, shut off all power to the circuit.

2. Select an appropriately sized U.L. (or ETL) approved LED Power Converter to safely drop the ship's supply voltage to a voltage regulated 24VDC. To do this, first determine the total power consumption (Watts) per circuit. An appropriately sized converter should have a rated power capacity equal to your fixtures' power requirements plus 10%. For a selection of approved LED Power Converters, please visit [www.imtra.com](http://www.imtra.com).

Example: A lighting circuit containing four 4' fixtures (25.6W/ea.) = 102.4W. Adding the 10% safety factor = 113W. You should use an LED Power Converter equal to or greater than 113W.

3. Connect ship's AC Line (Hot) and AC Neutral (Return) to the IN wires of the LED Power Converter and switch(es). Due to differences between EU (230V) and USA (120V) wire color coding, your ship's supply cables and input wires to the converter may not match. Black (or Brown = Line (Hot) and White (or Blue) = Neutral (Return).

4. Connect the LED Converter's 24VDC output red (positive) and black (negative) cables to the input supply wires of the AcXent LED fixture(s).

5. If you will be dimming your AcXent LED fixture, there are a few options available:

- A. Popular forward phase (Leading Edge) dimmers
- B. 0-10V or PWM Control (via centralized automated control system)

Note: Refer to wiring diagrams (Pages 7-10)

# WIRING INSTRUCTIONS (24VDC SUPPLY)

1. At the DC panel, shut off all power to the circuit.
2. Connect the ship's red (positive) and black (negative) wires to the DC/DC Power Conditioner.\*

\* Note : An approved DC/DC Power Conditioner must be used in order to uphold the warranty of this product. This device will assure a regulated and constant 24VDC supply that is required for proper operation and will protect the LED fixtures from a range of voltage issues including dips, spikes, and sustained low and high voltage transients. For a selection of different sized power conditioners, please visit our website at [www.imtra.com](http://www.imtra.com) or contact Imtra for assistance in selecting a properly sized unit.

3. Connect the black (negative) lead wires from the AcXent fixture(s) to the DC/DC Power Conditioner output negative terminal.
4. Connect the red (positive) lead from the fixture to the switch. Connect the DC/DC Power Conditioner output positive terminal to the other side of the switch.
5. If you will be dimming your AcXent LED fixture there are a few options available.
  - A. Digital DC Dimming with Imtra's Intervolt Switchmode Dimmer
  - B. IML 2-Wire LED Dimmer (available soon)

Note: Refer to wiring diagrams (Pages 11-13)

## Wiring Diagram

- 120/230V Supply
- No Dimming
- Single Switch Location

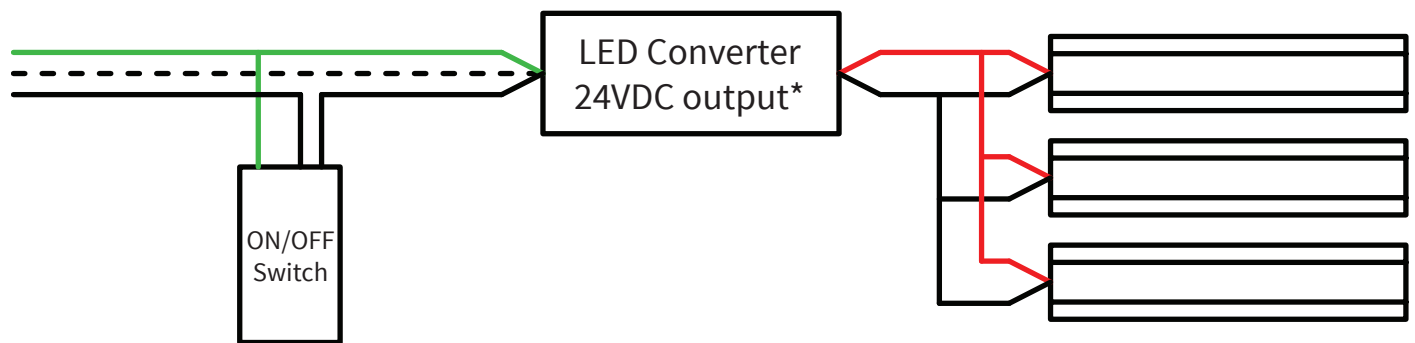

\*Imtra carries a full range of voltage-regulated LED Converters. Please visit [www.imtra.com](http://www.imtra.com)



## Wiring Diagram

- 120/230V Supply
- No Dimming
- Multiple Switch Locations

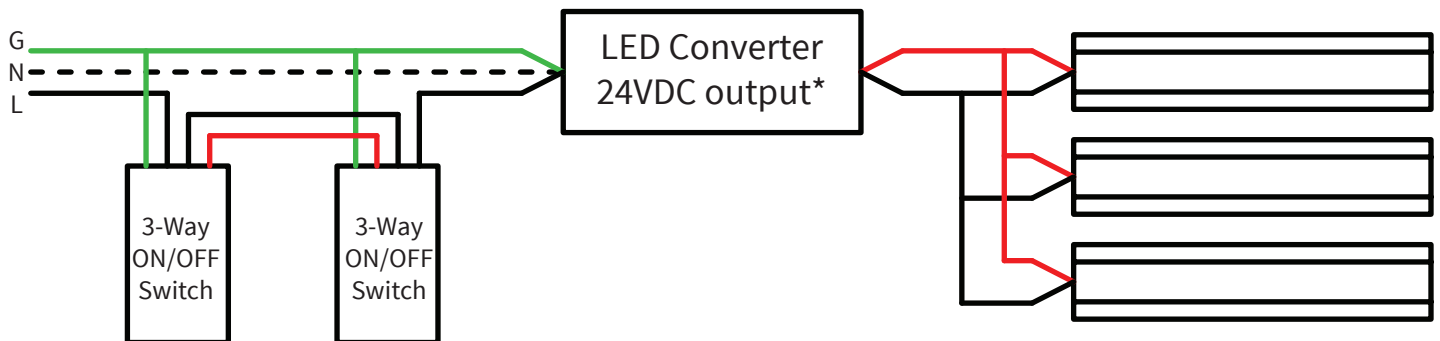

\*Imtra carries a full range of voltage-regulated LED Converters. Please visit [www.Imtra.com](http://www.Imtra.com)

## Wiring Diagram

- 120/230V Supply
- Trailing Edge ELV Dimmer

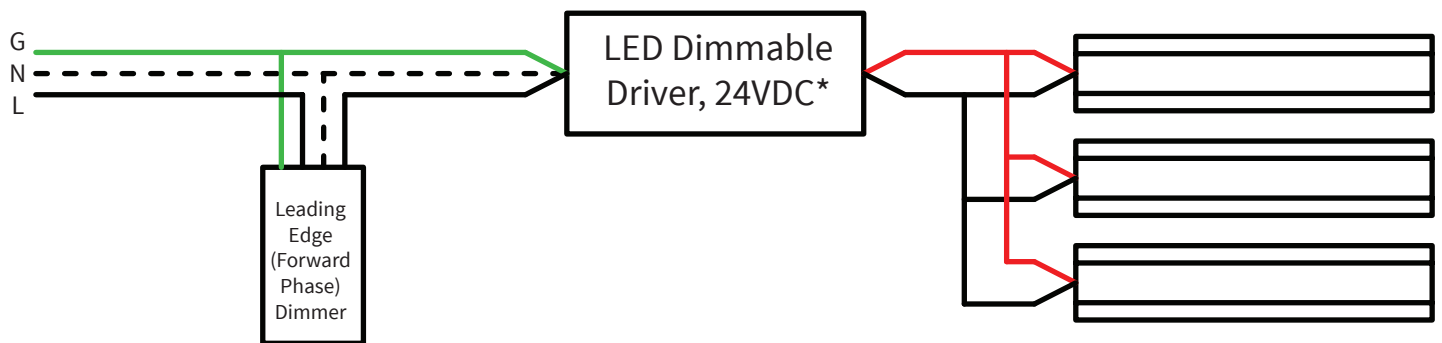

\*We recommend the Lutron Hi Lume A-Series Constant Voltage Driver. For more details along with a list of compatible dimmers, please refer to the AcXent Dimmable Driver Compatibility Chart.

## Wiring Diagram

- 120/230V Supply
- Centralized Automation & Control System

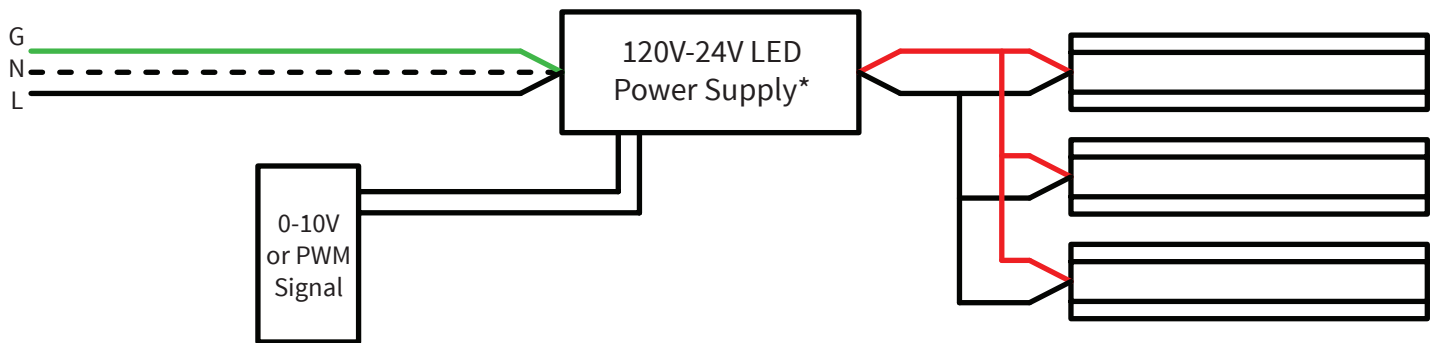

\*We recommend the Meanwell PWM-120-24 LED Power Supply. Please refer to the AcXent Dimmable Driver Compatibility Chart for more information.

## Wiring Diagram

- 24VDC Systems
- No Dimming
- Single Switch Location

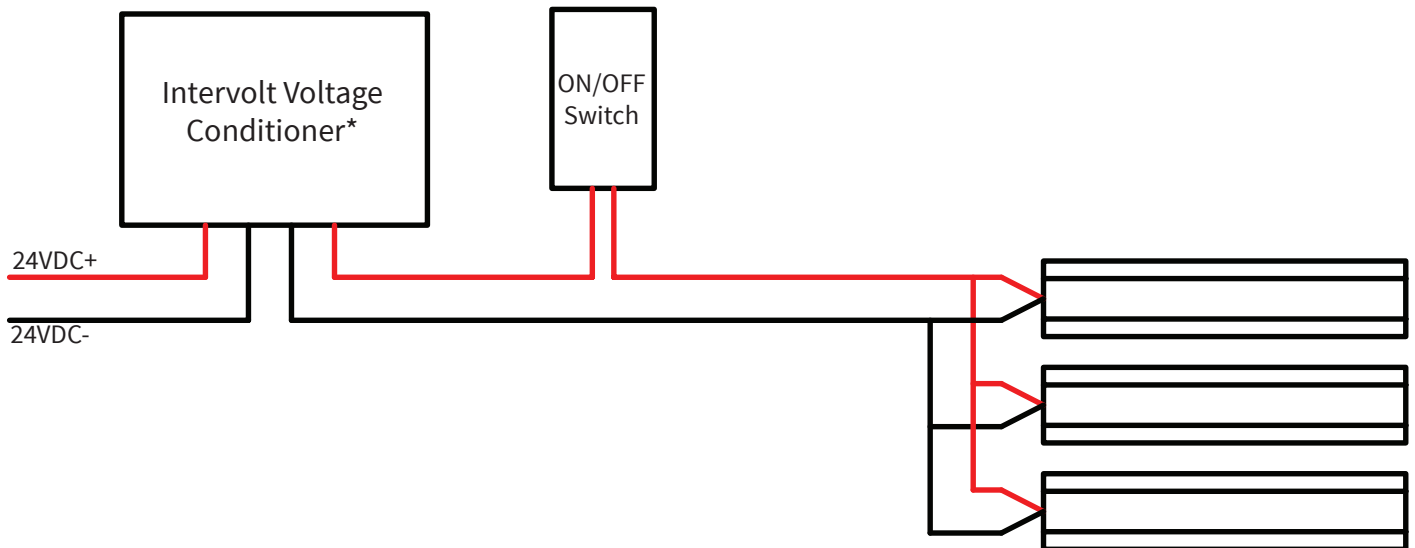

\*Imtra carries a full range of Power Conditioners and Voltage Stabilizers.  
Please visit [www.Imtra.com](http://www.Imtra.com)

## Wiring Diagram

- 24VDC Systems
- No Dimming
- Multiple switch Locations

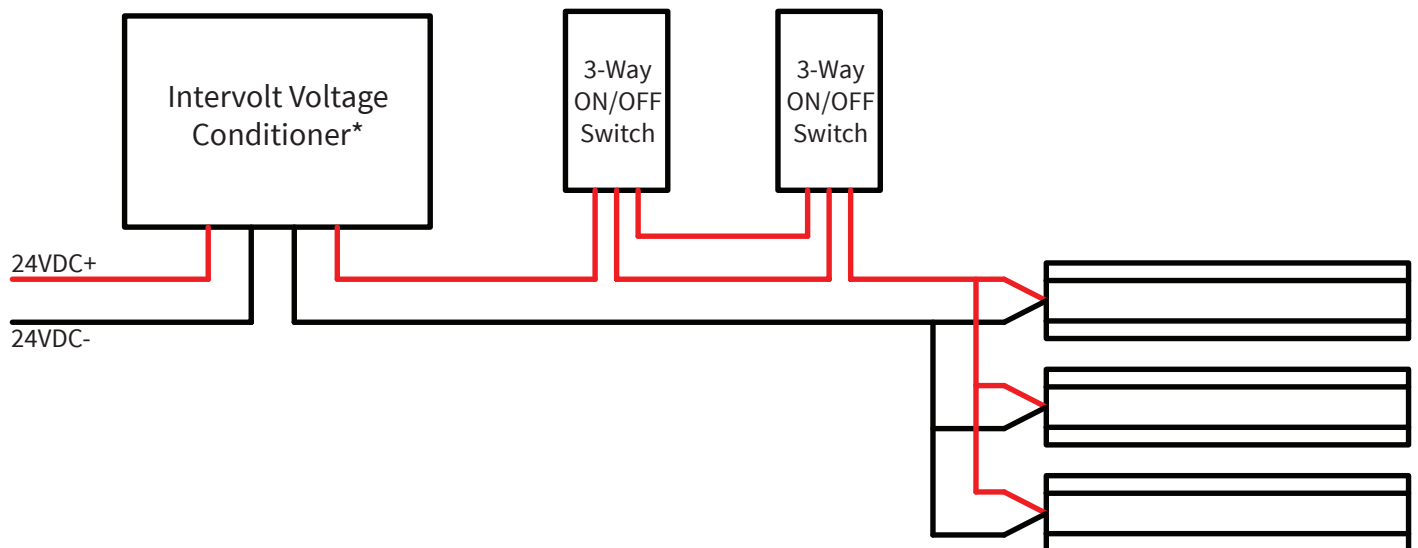

\*Imtra carries a full range of Power Conditioners and Voltage Stabilizers.  
Please visit [www.Imtra.com](http://www.Imtra.com)

## Wiring Diagram

- 24VDC Systems
- Dimming
- Multiple Switch Location (switches not shown)

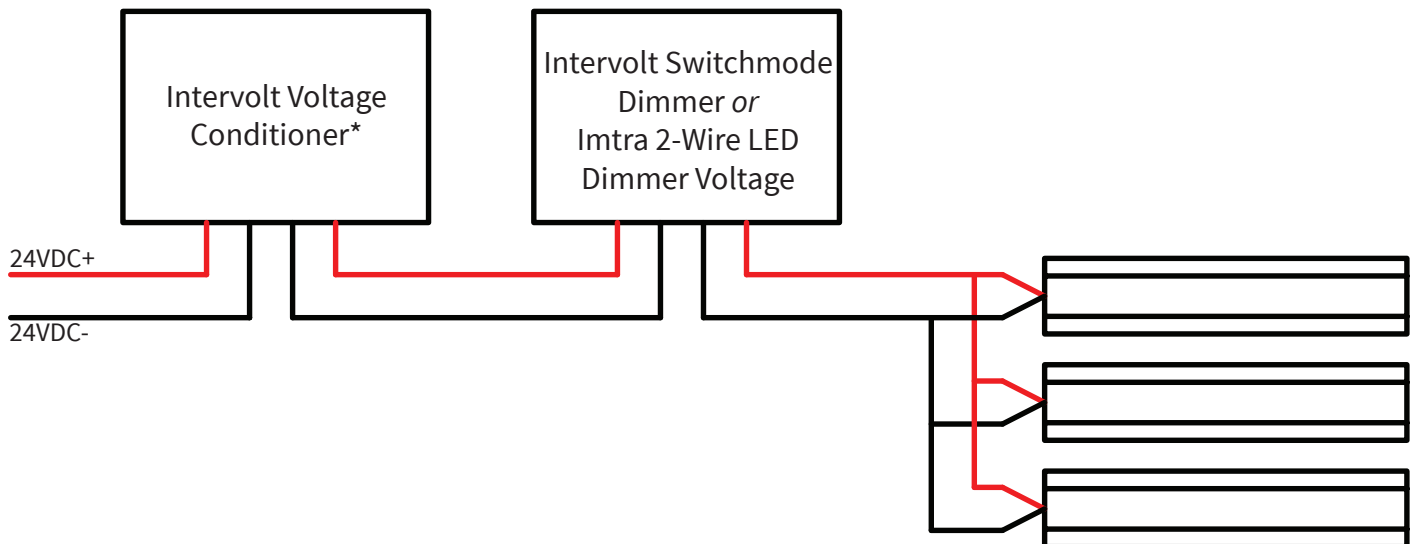

\*Imtra carries a full range of Power Conditioners and Voltage Stabilizers.  
Please visit [www.Imtra.com](http://www.Imtra.com)

# LIMITED WARRANTY

Imtra warrants the light-emitting LSA (LED subassembly) component of our IML PowerLED spot lights & fixtures for 5 years from the date of purchase. If the LSA should cease to function within 5 years, return the complete spot light assembly to Imtra for repair or replacement.

This warranty does not apply to damage resulting from actions of the user such as misuse, improper wiring/installation, operation outside of specification, improper maintenance or repair, unauthorized modification, lightning strike or damage from a power surge.

The trim ring (bezel) of the IML Power LED spot lights are warranted for one year.

Imtra specifically disclaims any implied warranties, merchantability or fitness for a specific purpose and will not be liable for any direct, indirect, incidental or consequential damages. Imtra's total liability is limited to repair or replacement of the product.

The warranty set forth above is inclusive and no other warranty, whether written or oral, is expressed or implied.

If it should become necessary to return a fixture for service during or beyond the warranty period, please refer to Imtra's standard Return Policy as detailed on Imtra's website ([www.imtra.com](http://www.imtra.com)) or call Imtra customer service at (508) 995-7000.

No returns are accepted without a Return Authorization (RA) number.



30 Samuel Barnet Boulevard, New Bedford, MA 02745

(508) 995-7000 • [www.imtra.com](http://www.imtra.com)