



Sigma PowerLED Downlight Installation and Operation Manual



Sigma
Small



Sigma
Large



Sigma
Surface-Mount

OVERVIEW

Imtra PowerLED fixtures are uniquely suited for marine, automotive and architectural lighting applications. They have been engineered specifically to take advantage of the latest LED (Light Emitting Diode) technology offering superior reliability, minimal power consumption and far less radiated heat than traditional incandescent light sources. When installed properly, these products will provide years of flawless performance.

The Sigma series encompasses a common LSA (LED sub-assembly) platform with different bezel options allowing the user to choose a model that can easily replace existing lights whether these are traditional halogen or older LED lights. The flush mount models are provided with stainless steel mounting springs which may be easily removed if a screw mount installation is required.

Sigma Small fits flush into a very common hole cutout size; may be either screw or spring mounted.

Sigma Large shares the same light engine but is equipped with a special adapter plate and larger diameter trim ring to fit a range of larger hole cutout sizes; may be screw or spring mounted.

- 1 -

Sigma Surface-Mount shares the same light engine and features a sleek mounting bezel for installation where recessing is not possible.

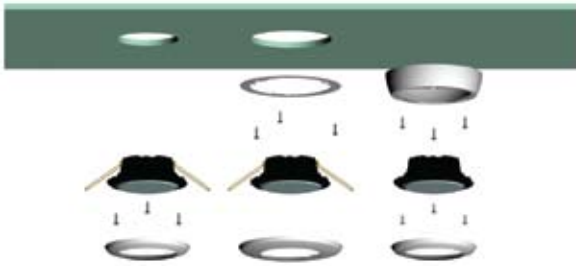

Sigma is a 2-wire dimmable product that simplifies retrofit installations by allowing the installer to take advantage of the vessel's existing two wires (or duplex cabling). Sigma is also compatible with some existing halogen dimmers which may further simplify installation and minimize the project's wiring complexity. Sigma's integrated low voltage AC bridge rectifier permits its use with either 10-40VDC or 12V/24VAC supplied by magnetic transformers.

- 2 -

SPECIFICATIONS

	Sigma Small	Sigma Large	Sigma Surface-Mount
Trim Ring Diameter	3.57" (91mm)	4.35" (110mm)	3.57" (91mm)
Mounting Base Diam.	N/A	N/A	4.07" (103mm)
Bezel Height	0.34" (9mm)	0.34" (9mm)	1.25" (32mm)
Cutout Diameter	2.56" (65mm)	2.56" (65mm) to 3.42" (87mm)	N/A
Recess Depth	0.90" (23mm)	0.90" (23mm)	N/A
Input Voltage Range	10-40V (AC/DC)		
Power Consumption	5.0 Watts		
IP Rating	IP65*		

* IP65: "Protected from the ingress of dust and low pressure jets of water from all directions"

- 3 -

PHYSICAL INSTALLATION

Whether the lights are installed using the springs provided or by screw-mounting, it is imperative that the lights be mounted in such a location that the fixtures are protected from the rear against water exposure.



Also, it is important that the lights are mounted with airspace around the heat sink housing to allow for convective cooling of the lights. For recessed applications (this does not apply for surface-mount installations), we recommend a distance of 1/2" (13mm) of free space above the housing.

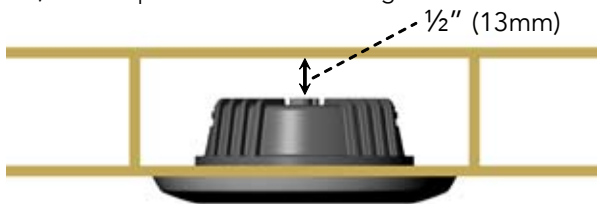

- 4 -

Installation Instructions (Recessed Mount)

Sigma Small and Sigma Large come with mounting springs installed. If your application requires a screw-mount installation, you will need to remove the springs. This can be done by first squeezing the coils together and then angling the free side up and away from the spring retaining tabs. (See Figure 1)

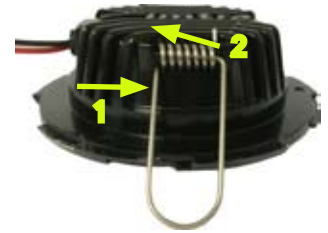

Figure 1

1. If this is a new installation (i.e. no existing hole), then cut a hole in the mounting surface according to the cutout diameter required for the light (see chart on page 3). If this is a refit (i.e. an existing hole), proceed to the next step.
2. Connect the light to a low voltage power source following the wiring instructions in the next section of this guide.
3. Once all electrical connections are made and secure, proceed accordingly:

- 5 -

A. Spring-Mount Version (Small or Large): With trim ring attached, gently bend back the mounting springs on the Sigma and insert the spring tips into the cutout hole in the mounting surface (see Figure 2).

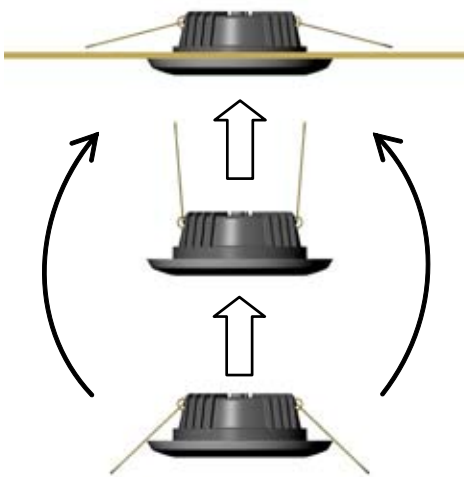

Figure 2

- 6 -

B. Screw-Mount Version (Small or Large): Twist and remove the trim ring on the Sigma and insert it into the cutout hole in the mounting surface. Fasten with three #4 flat head screws (see Figure 3). Place the trim ring over the light making sure the tabs of the trim ring engage with the openings in the housing. Twist the trim ring on to secure it.

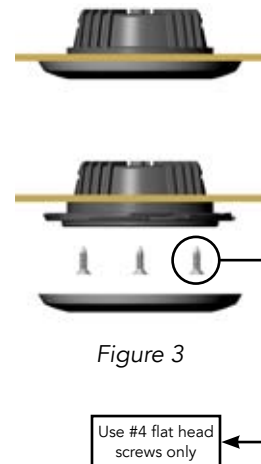

Figure 3

Use #4 flat head screws only

- 7 -

Installation Instructions (Surface-Mount)

1. Position mounting base in desired location and secure using (3) #4 flat head screws.
2. Twist and remove the trim ring from the LED subassembly. Connect the LED subassembly to a DC power source by passing the wires through the mounting base following the wiring instructions in the next section of this guide.
3. Once all electrical connections are made, place the LED subassembly housing into the mounting base, line up the holes, and secure with (3) machine screws (included). (see Figure 4).
4. Place the trim ring over the light making sure the tabs of the trim ring engage with the openings in the housing. Twist the trim ring on to secure it.



Figure 4

- 8 -

WIRING INSTRUCTIONS

Sigma may be controlled by either basic on/off or by a remote dimmer. Both the power (on/off) and dimming function is achieved with the two lead wires provided.

1. Connect the light to a DC (or low voltage AC*) power source. Connect the red wire to positive DC voltage and the black wire to negative or ground.

**Note: Magnetic transformers only*

2. Dimmer compatibility: If you are replacing halogen or incandescent fixtures that use a remote DC dimmer, your new lights will use the same power/control wires but may or may not be compatible with the existing dimmer. If after testing your lights with the existing DC dimmer you are not satisfied with the performance, then we recommend the use of Imtra's Intervolt DC Dimmer which these lights have been optimized for. Please contact Imtra or visit our website for details on this dimmer.
3. Transformer compatibility: Sigma is designed to work with 10-40VDC as well as low voltage AC (from a magnetic transformer) but on non-dimming circuits only. Electronic

- 9 -

transformers are not compatible. If dimming is required, then the transformers may be replaced with LED converters sized appropriately. Please contact Imtra for assistance.

Wire	Function
Red	+ Dim/Power
Black	- Dim/Power

NOTES ON WIRE SIZE

The PowerLED family of products comes equipped with integrated driver electronics. These components are sensitive to DC systems with voltage drops. Therefore, it is imperative to select the correct wire size to supply DC voltage to the lights. This prevents excessive impedance and voltage drops which can cause premature failure in the PowerLEDs. It is recommended that the supply wire size be selected according to the ABYC Wiring Recommendations Chart for a 10% voltage drop. These charts can be found at www.imtra.com.

- 10 -

Wiring Diagram

- No Dimming
- Single Switch Location

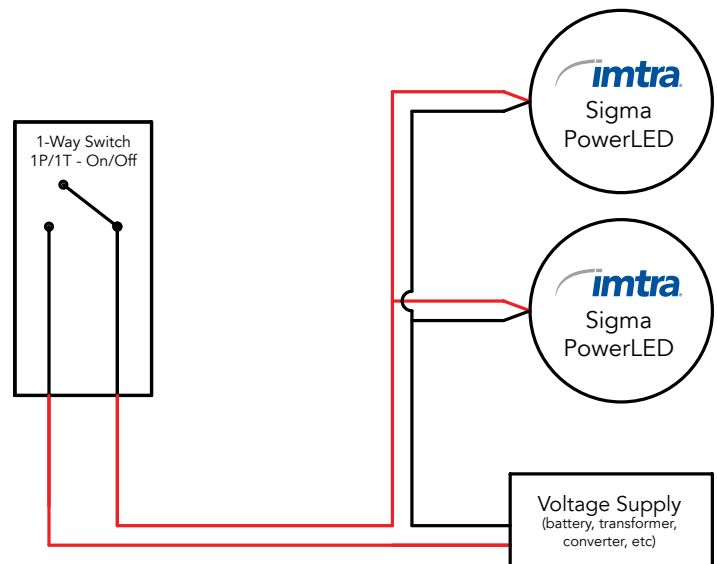

- 11 -

Wiring Diagram

- No Dimming
- Multiple Switch Location

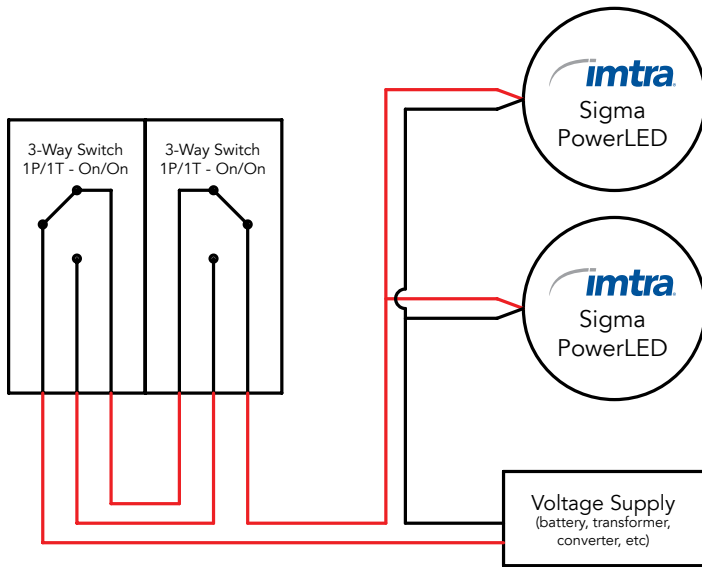

- 12 -

Wiring Diagram

- With Compatible Halogen Dimmer (IMTRA Intervolt or similar)

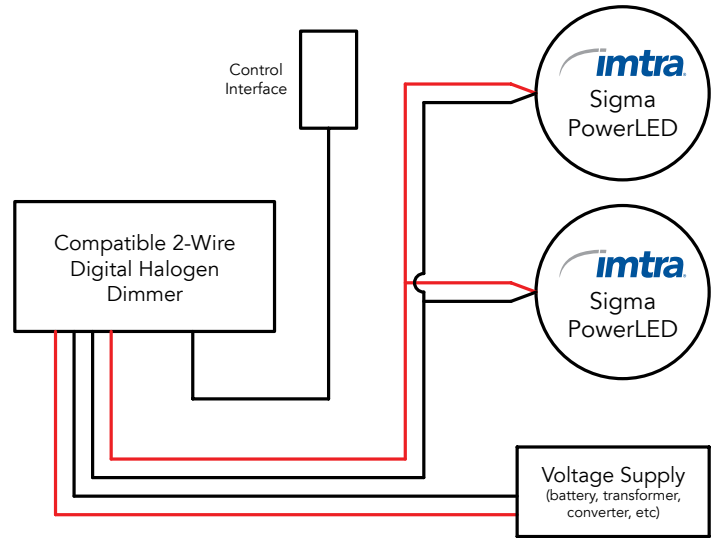

- 13 -

LIMITED WARRANTY

Imtra warrants the light-emitting LSA (LED subassembly) component of our IML PowerLED spot lights & fixtures for 5 years from the date of purchase. If the LSA should cease to function within 5 years, return the complete spot light assembly to Imtra for repair or replacement.

This warranty does not apply to damage resulting from actions of the user such as misuse, improper wiring/installation, operation outside of specification, improper maintenance or repair, unauthorized modification, lightning strike or damage from a power surge.

The trim ring (bezel) of the IML Power LED spot lights are warranted for one year.

Imtra specifically disclaims any implied warranties, merchantability or fitness for a specific purpose and will not be liable for any direct, indirect, incidental or consequential damages. Imtra's total liability is limited to repair or replacement of the product.

The warranty set forth above is inclusive and no other warranty, whether written or oral, is expressed or implied.

If it should become necessary to return a fixture for service during or beyond the warranty period, please refer to Imtra's standard Return Policy as detailed on Imtra's website (www.imtra.com) or call Imtra customer service at (508) 995-7000.

No returns are accepted without a Return Authorization (RA) number.

- 14 -



30 Barnet Boulevard, New Bedford, MA 02745

(508) 995-7000 • www.imtra.com